



Pellets Conveyor VSF 501 / VSF 750

Application Area

The conveyors of the **VSF 501/750** models are used to convey all kinds of plastics pellets. The products are equipped with a side canal compressor and are used for the automatic filling of plastics processing machines. The GERCO pellets conveyors have special pick-up elements to connect the conveyor machine and the dryer. They have a maximum conveying capacity of 500/700 kg/h.

By attaching the add-on assembly groups **Two Components Switch and/or Air pressure filter, dedusting** an extended application of the conveying unit is possible.



Standard Features:

- Stainless steel material precipitator container
- Fan and control unit (side canal compressor), with electronic control
- Conveying time and conveying cycle can be adjusted separately
- Suction lance \varnothing 40
- Delivery hose and return air hose made off PU

Product Information

Technical Data

Mechanical Data

	VSF 501	VSF 750
Dimensions (ø x H) in mm hopper	280 x 710	280 x 710
Dimensions of fan (W/D/H)	365 x 370 x 650	365 x 370 x 650
Weight in kg	26	26
Conveying performance in kg / h	500	750
Conveying height in m	5	5
Conveying length in m	15	15
Container capacity in liter	20	20
Blower connection	Ø40	Ø40
Material connection	Ø50	Ø50
Noise level 1 meter distance dB	73	73

Hopper flange

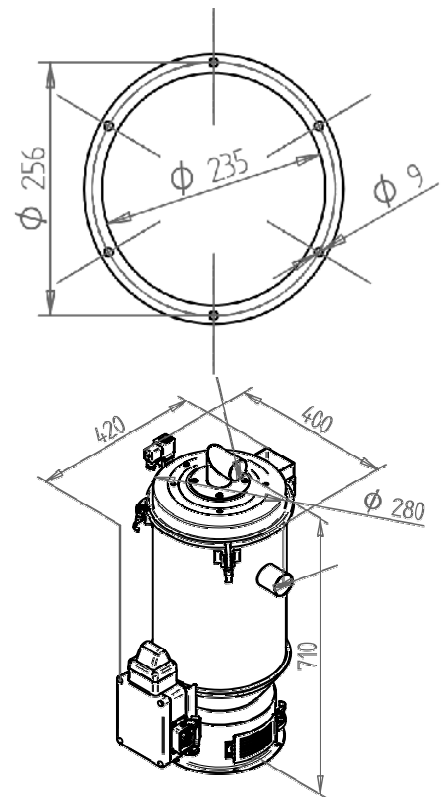

Electrical Data

Connected load	3 x 400 V, 50 Hz	3 x 400 V, 50 Hz
Fan power in kW	2,2	4,0

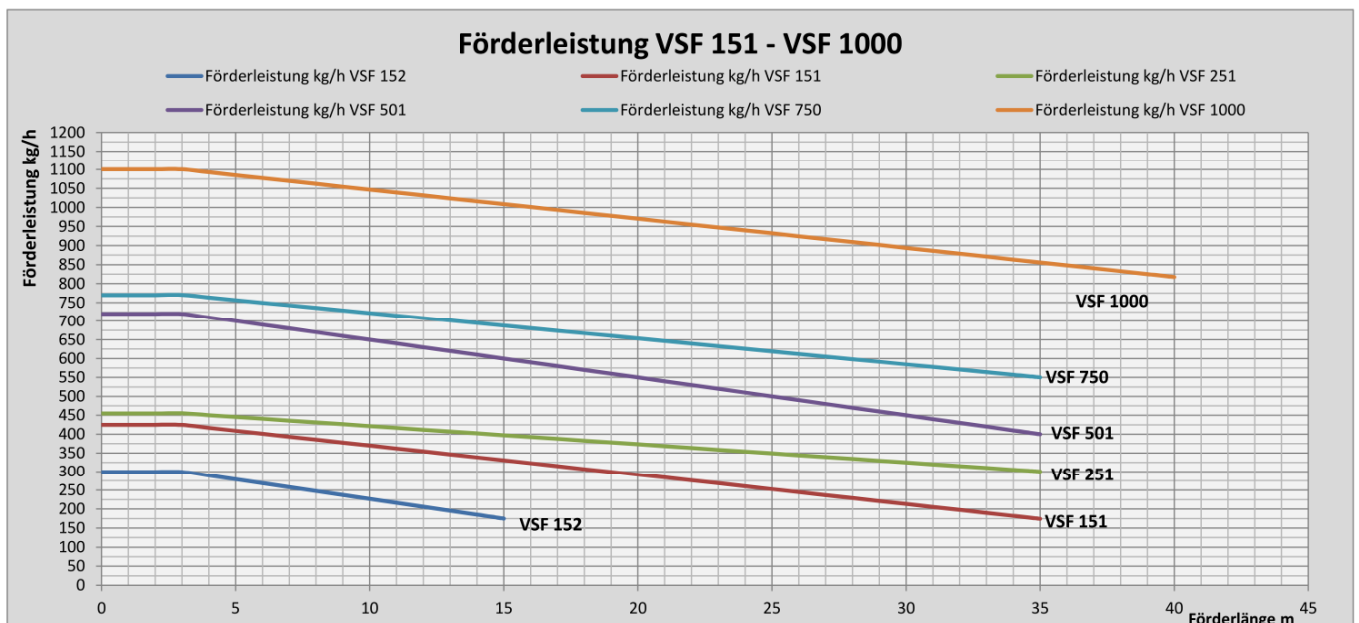

Accessories

Two components switch ZKW 22

to convey two materials in the VSF 150 und VSF 250

Air pressure filter dedusting DLA 02

for filter dedusting of VSF 150 and VSF 250

Flashlight

Adapter container in different volume