

# Product Information

## Desiccant dryer GTT 401 EST

### Application Area

The GTT 401 EST dryer is a compact one-chamber desiccant dryer. It is suited to dry all plastics fully automatically if they do not emit volatile components\* other than water during the drying process. The dryer works in a temperature range between 60 and 160 °C, +/- 2 °C. Residual moisture of < 0.02 % can be achieved. It consists of a dry air generator, a heatable material container and the automatic control which is situated in the switch box on the side. The functional diagram (see drawing below) shows the principle of the drying process of a desiccant dryer. Partial air flow is directed through two desiccant chambers. One chamber is located in the drying cycle and dehumidifies the air that comes out of the desiccant chamber. The second is regenerated at a temperature of 280 °C. Automatic operation of the regenerating, cooling and drying phases is achieved by the time control which is integrated in the SPS.

\*Please ask the producer of the material for the characteristics of the drying material.



1. Fan
2. Regeneration heater
3. Waste air valve
4. Molecular sieve
5. Engine valve
6. Granulate material heating
7. Material container
8. Air circulation filter
9. Air circulation cooler

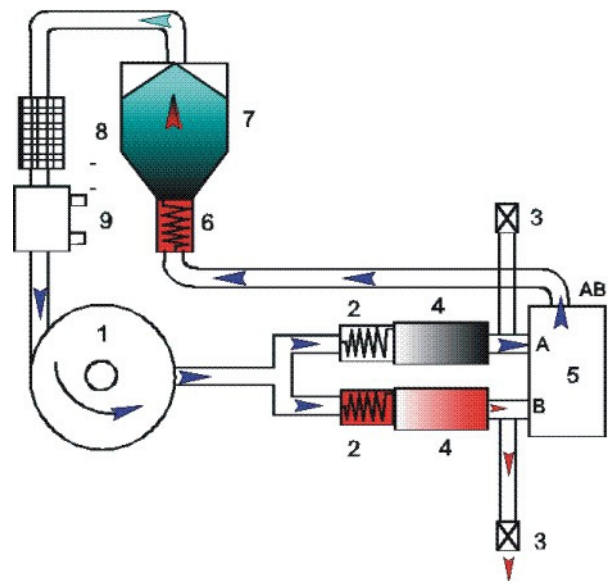

### Standard Features:

- Siemens Touchpanel 4,3" mit SPS S7-1200 CPU
- Mobile compact installation of 400 liter capacity with insulated container
- Automatic control in the side of the unit attached cabinet
- Automatic fan runs after turning off the dryer.
- Time switch
- Temperature-granulate container controlled by the integrated PLC.
- Removable sieve container made of stainless steel 1.4301
- Easily accessible and replaceable air filter
- Unloading device and Saugfördereranschlußaufnahme the outlet slide
- Bicameral dry air unit for continuous drying of the granulate
- Air-air heat exchanger for the return cooling.- no water connection necessary

# Product Information

## Technical Data

### Mechanical Data

Dimension (H/W/D) mm	1870x1100x1320
Cover filling height mm	1765
Weight in kg	360
Capacity in liter	400
Dry-bulb temperature in °C	60 - 160
Residual moisture in %	< 0,02
Drying capacity in kg/h	60 - 240

### Electrical Data

Connection load V / Hz	3 x 400 / 50
Power consumption in kW	16,2
Current consumption in A	27
Regeneration heater in kW	3,50
Granular material heater in kW	11,0
Fan power in kW	1,50
Fan flow rate in m³/h	210

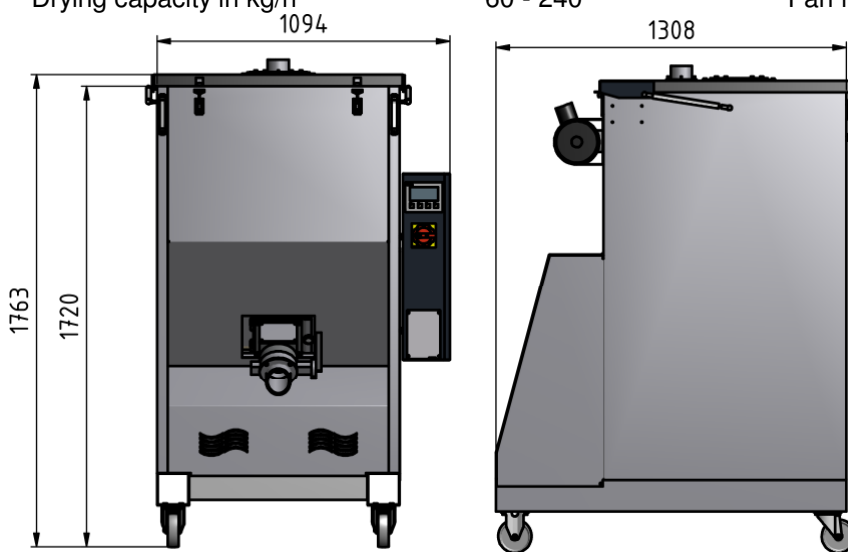

## GTT 401 EST

The dryer is equipped with RAL 7004 light gray textured paint and the equipment cabinet and cover with RAL 7016 dark gray finish.

Other color shades and operating voltage can be selected at an additional charge if required.

## Accessories

### Dew point regeneration

The dew point sensor is built into the dryer. The dew point is shown in the SPS touch panel. The regeneration happens depending on the dew point. Due to the dew point dependent regeneration, it only takes a regeneration of the molecular sieve when the dew point rises above a certain value. Because of the extended cycling time of the regeneration a significant saving of energy is occurred.

### Overdrying protection

The over-drying protection protects the material to be dried granules against over-drying and minimizes the energy consumption of the dryer.

The return air of disiccant dryer is monitored in terms of temperature. Achieved the return air temperature a preset limit, the granule heating is switched off. The dry air continues to circulate so that the granules can absorb any moisture. After falling below the fixed limit temperature, the heating is switched on again.