

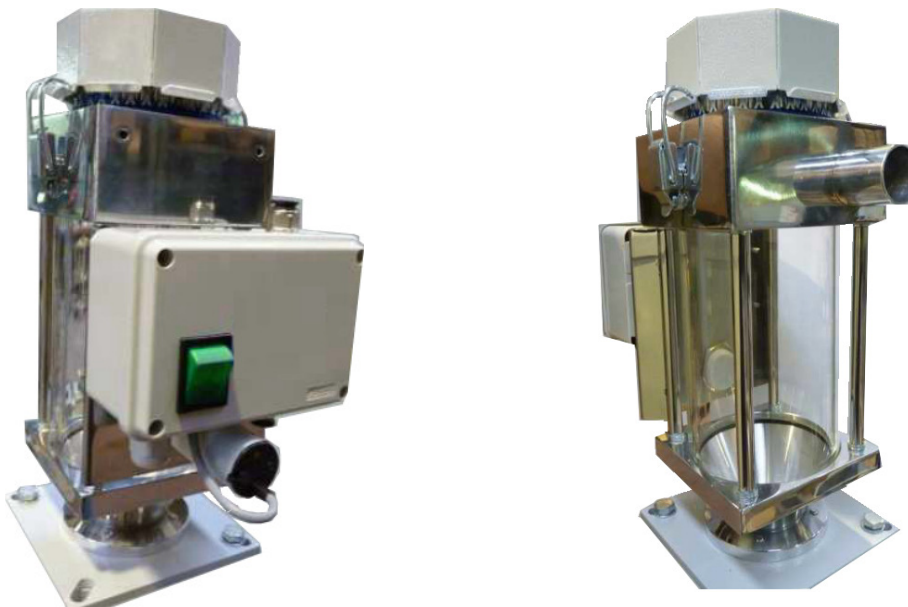

Injector Conveyor Device IF 01 / IF 03

Application Area

The Gerco injector conveyor of the class IF are used for the support for all plastic granulate materials. The devices work according to the venturi principal with air pressure and serve for the automatic filling of GERCO – gto dryer with a max. single container volume of 50 litres and plastic processing machines.. The GERCO – granulate material dryers own special admission elements to the connection of conveyor device and dryer



Standard Features:

- Hopper loader from aluminium and borosilicate glass
- Capacitive fill level detectors
- Simply to be cleaned paper filter
- Injector nozzle with an air hose $\varnothing 30$
- 3 meter conveying hose from **PU** $\varnothing 30$ with a steel spiral

Product Information

Technical Data

Mechanical Data

	IF 01	IF 03
Dimensions (ø x H) in mm hopper	130x202x214	130x205x310
Weight in kg	2,5	3
Conveying performance in kg / h	20	40
Conveying height in m	2	2
Conveying length in m	3	3
Container capacity in liter	1	3
Injector nozzle ø	30	30

Hopper flange

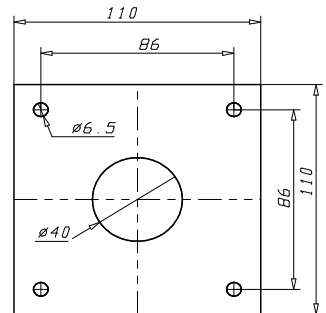

Electrical Data

Connection load	1 x 230 V, 50 Hz	
Compressed air bar min.	6	6

Inclusive injector nozzle und 3 meter hose

