

Product Information

Volumetric metering unit GVD 51

Application Area

The volumetric metering unit GVD 51 is suited for the production of pellets / master batches in batches of 25–180 kg / h. Because of its construction and its modular build-up it is both easy to use and can be cleaned quickly. The machine consists of the base module to which both the container for the pellets and the funnel is flanged. The control is located in a separate body. The digital display allows for an uncomplicated adjustment of the dosage ratio. The GVD 51 is suited the for injection molding and the application in extrusion facilities. For complete automatic use of this machine there is the possibility to convey with a pneumatic conveyor.

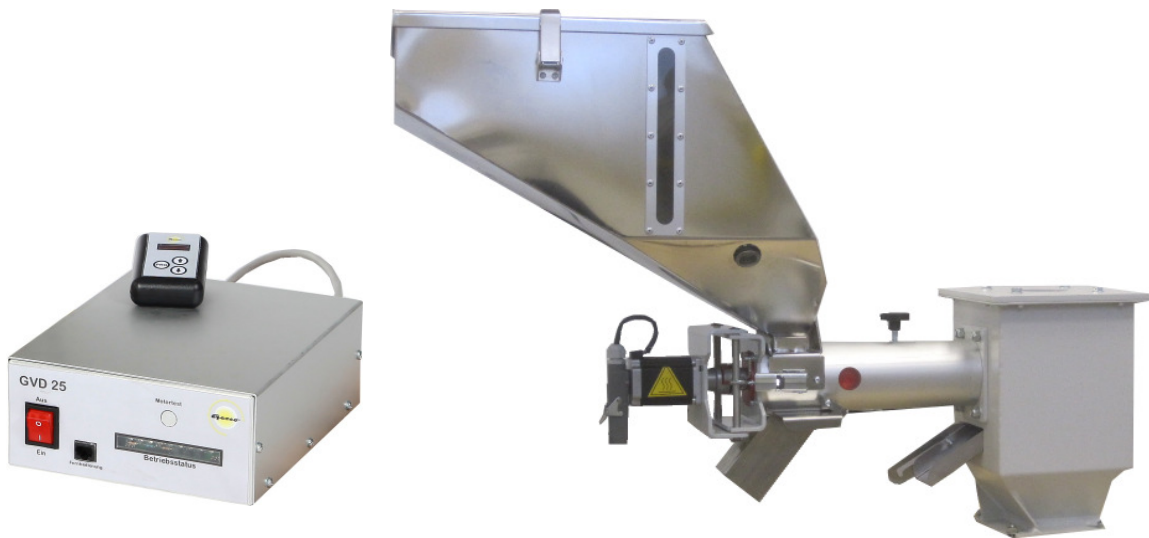

Diagram: GVD 25 & MB 15

Standard Features:

- Base module with flange and sample slide
- Metering device with engine
- Funnel for dosages (Master batch)
- Control unit with digital display
- All components that get in touch with the material are stainless steel

Product Information

Technical Data

Mechanical Data

Dimension (H/W/D) in mm	652 x 970 x 390
Weight kg	28
Dosing performance in g / s	7-50 (25 –180kg/h)
Container volume (tank dosing) in liter	40
Engine torque Nm	2,6

Electrical Data

Connection load V / Hz	230 / 50-60
Power consumption W	920
Control	Microprozessor

Volumetric metering unit GVD 51

Accessories

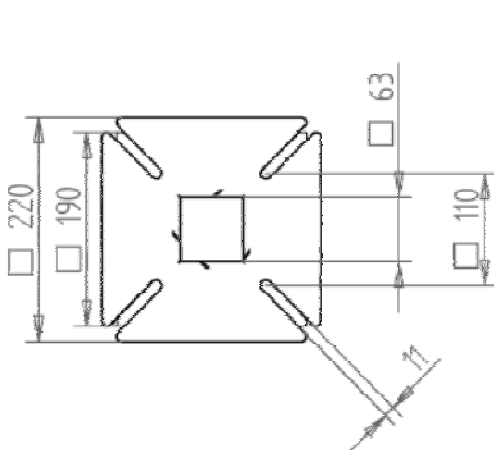

Hauptkomponente Auslauf

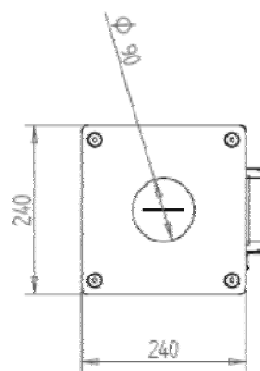

Hauptkomponente Zulauf

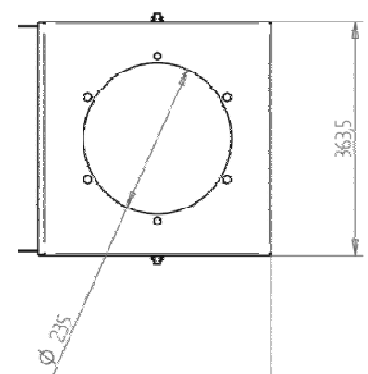

Mischkomponente Fördererflansch